



2019 Hong Kong Mathematics Kangaroo Contest

— Benjamin —

2019香港數學袋鼠競賽

【小學高年級】

Instruction 說明

1. DO NOT FLIP OPEN THIS FRONT COVER UNTIL YOUR PROCTOR TELLS YOU.
在未收到監考老師指示前，請不要翻開此封面。
2. This is a 30 question multiple choice test. For each question, only one answer choice is correct.
這是一套包括30道選擇題的測試，每道題目只有一個正確答案。
3. Each question is given a point value. You will receive full points for correct answer, and zero point for blank or incorrect answer. The full score of this test is 120 points.
每道題目都有給定的分值，答對得滿分，答錯或空白得0分。本次測試的滿分為120分。
4. Mark your answer to each problem on the answer form with a #2 pencil. Check the blackened circles for accuracy and erase errors and stray marks completely. Only answers properly marked on the answer form will be scored.
請將每道題目的答案用#2鉛筆標註在答題卡上。請注意檢查塗寫的黑色圓圈的準確性，用橡皮完全擦掉錯誤的答案和多餘的標記。只有恰當標註在答題卡上的答案才會被評分。
5. Only scratch paper, graph paper, rulers, protractors, and erasers are allowed as aids. Calculators are NOT allowed. No problems on the test *require* the use of a calculator.
只能使用草稿紙、方格紙、尺、量角器和橡皮作為輔助工具。計算器是不允許使用的。測試中沒有任何問題必須需要使用計算器。
6. Figures are not necessarily drawn to scale.
圖形不一定按比例繪製。
7. Before beginning the test, make sure to record your name, school name and Competition ID on the answer form, especially to bubble in the 8-digit Competition ID completely!
在開始測試之前，請確保已將你的名字，校名和准考證號填寫在答題卡上，特別是8位准考證號的每位數字已經塗好相應的黑色圓圈。
8. You will have 75 minutes to complete the test once your proctor tells you to begin.
監考老師宣布開始後，你將有75分鐘的時間完成測試。

Part 1: 10 problems, 3 points each 第一部分：10道題目，每題3分
--

1. Carrie has started to draw a cat.
Carrie開始畫一隻貓。

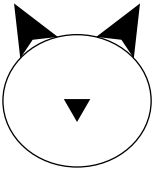

She finishes her drawing by adding more color. Which of the figures below can be her drawing?
她通過添加更多顏色來完成繪圖。問下面的哪個圖形可能是她的圖畫？

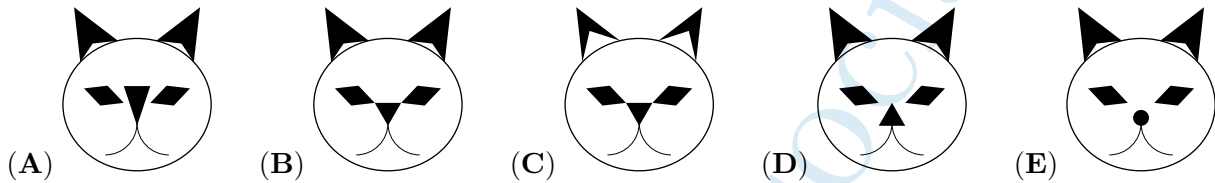

2. The Mayan people wrote numbers with dots and bars. A dot is written for 1 and a bar for 5.
How did they write 17?

瑪雅人用點和條來表示數。一個點代表1，一個長條代表5。問他們應該怎麼寫17？

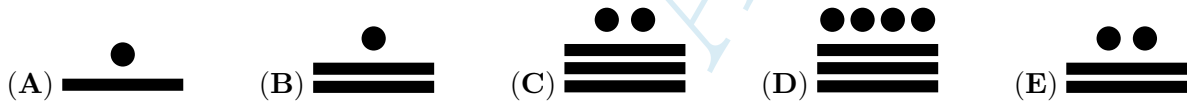

3. A digital clock shows the time 20:19. What will the clock show the next time it uses the same digits?

數字時鐘顯示時間20:19。時鐘在下次使用同樣的這些數字時會顯示幾點？

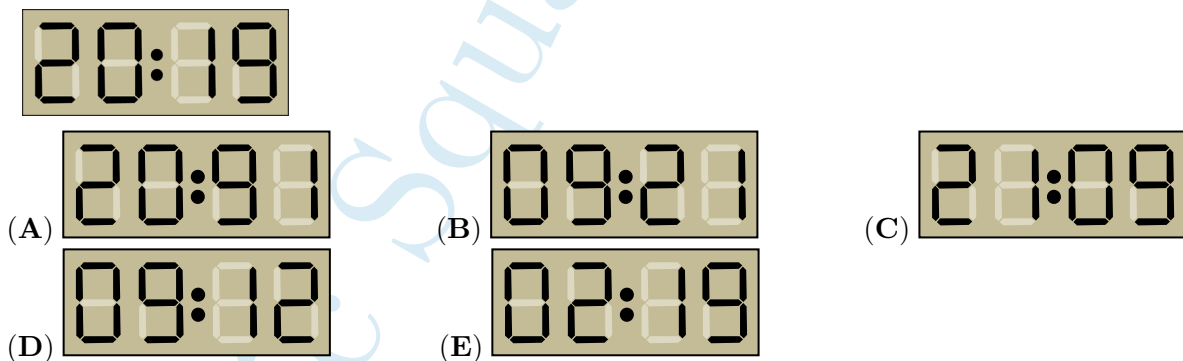

4. There are 14 girls and 12 boys in a kindergarten. If half of the children go for a walk, at least how many of them are girls?

幼兒園裡有14個女孩和12個男孩。如果有一半的孩子去散步，那麼其中最少有多少個女孩？

- (A) 5 (B) 4 (C) 3 (D) 2 (E) 1

5. The sum of the dots on opposite faces of an ordinary dice is equal to 7. Which of the following shows the ordinary one?

普通的骰子相對面上的點數之和等於7。問以下哪一個顯示的是普通的骰子？

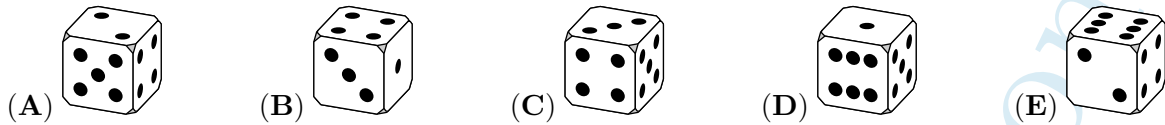

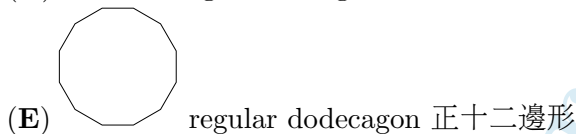
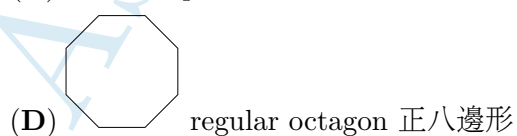
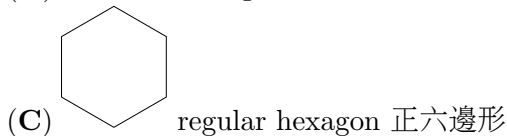
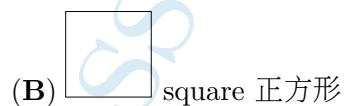
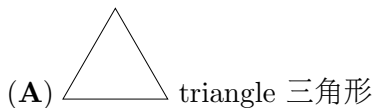
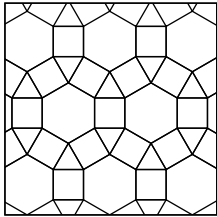

6. Which of the following geometric figures is not in this design?

以下哪個幾何圖形不在這個設計圖案中？

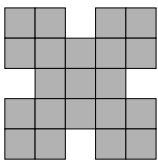

7.



Laura wants to colour a 2×2 square  of the above figure. How many possibilities are there?

Laura 想要給上述圖形中的一個 2×2 正方形  塗色。共有多少種可能性？

- (A) 5 (B) 6 (C) 7 (D) 8 (E) 9

8. The 6 smallest odd natural numbers are written on the faces of a dice. Toni throws it three times and adds the results. Which of the following numbers cannot be the sum?

將最小的6個奇自然數寫在一個骰子的各個面上。Toni 拋擲了這個骰子三次，並且將所得的結果相加。以下哪個數不可能是這個和？

- (A) 21 (B) 3 (C) 20 (D) 19 (E) 29

9. The sum of the ages of a group of kangaroos is 36 years. In two years time the sum of their ages will be 60 years. How many kangaroos are in that group?

一群袋鼠的年齡總和為36年。兩年以後，他們的年齡總和將變成60年。問這群袋鼠共有多少只？

- (A) 10 (B) 12 (C) 15 (D) 20 (E) 24

10. Michael paints the following buildings made up of identical cubes. Their bases are made of 8 cubes. Which building needs the most paint?

Michael給由相同立方體組成的以下構件塗油漆。它們的底座都是由8個立方體組成。問哪個構件需要最多的油漆？

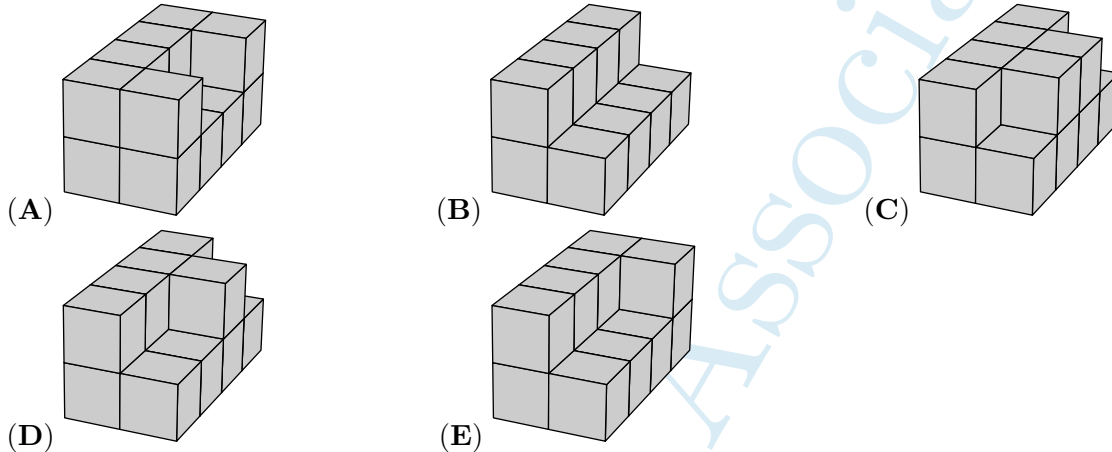

Part 2: 10 problems, 4 points each | 第二部分：10道題目，每題4分

11. On each of three pieces of paper a three digit number is written. Two of the digits are covered. The sum of the three numbers is 826. What is the sum of the two covered digits?

三張紙片每一張紙上寫有一個三位數。其中有兩個數字被遮住了。這三個數的總和是826。問這兩個被遮住的數字的和是多少？

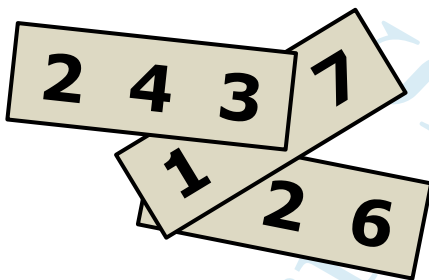

- (A) 7 (B) 8 (C) 9 (D) 10 (E) 11

12. Riri the frog usually eats 5 spiders a day. When Riri is very hungry, she eats 10 spiders a day. She ate 60 spiders in 9 days. How many days was she very hungry?

青蛙Riri通常每天吃5只蜘蛛。當Riri在很飢餓的狀態時，她每天吃10只蜘蛛。她在9天吃了60只蜘蛛。問她有幾天很飢餓？

- (A) 1 (B) 2 (C) 3 (D) 6 (E) 9

13. Pia plays with a yardstick consisting of 10 sticks (see picture). Which of the following figures cannot be formed with this yardstick?

Pia在玩一個由10節棍子組成的標尺（見圖）。下面哪個圖形無法用這個標尺拼出？

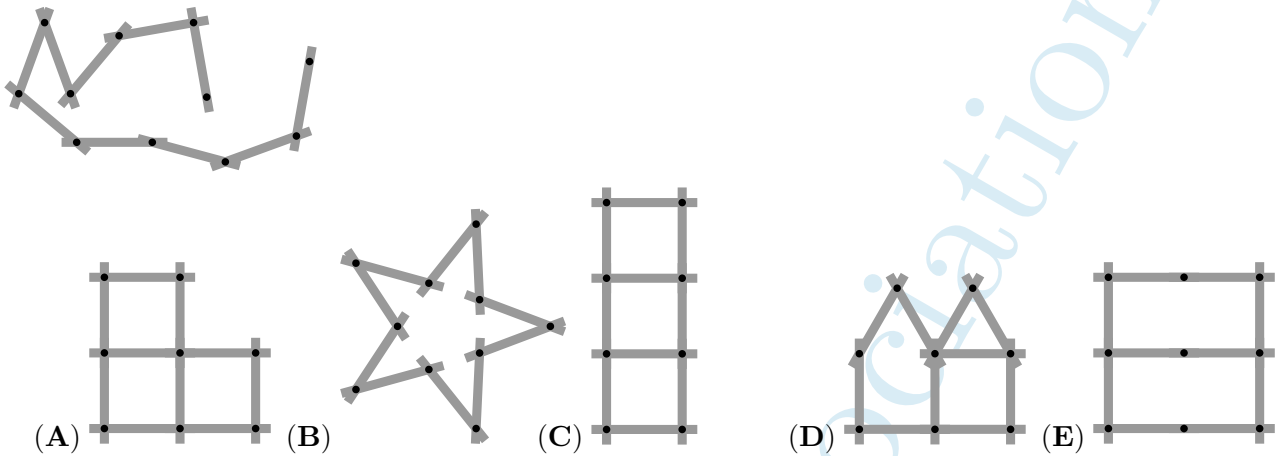

14. Five equal squares are divided into smaller squares. Which square has the largest black area?
五個相同的正方形被切成了小正方形。問哪個正方形中黑色部分的面積最大？

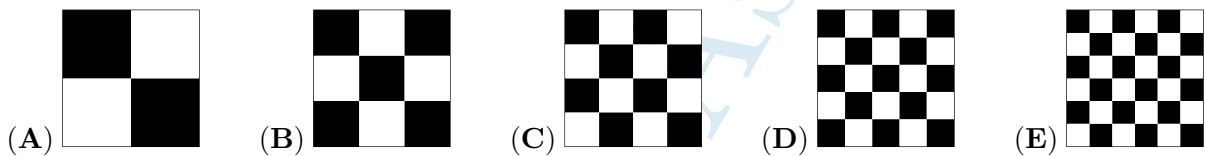

15. A big triangle is divided into equilateral triangles as in the figure. The side of the small gray triangle is 1 meter. What is the perimeter of the big triangle in meters?

如圖所示，一個大三角形被分割成若干個等邊三角形。灰色小三角形的邊長為1米。問大三角形的周長是多少米？

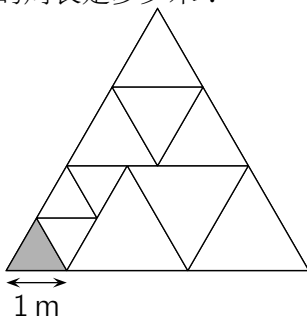

- (A) 15 (B) 17 (C) 18 (D) 20 (E) 21

16. In the garden of a witch there are 30 animals: dogs, cats and mice. The witch turns 6 dogs into cats. Then she turns 5 cats into mice. Now her garden has the same number of dogs, cats and mice. How many cats were there at the beginning?

女巫的花園裡有30只動物：狗，貓和老鼠。女巫將6隻狗變成了貓。然後她把5隻貓變成了老鼠。現在她的花園裡有相同數量的狗，貓和老鼠。問開始時有多少隻貓？

- (A) 4 (B) 5 (C) 9 (D) 10 (E) 11

17. With blocks of dimension $1\text{cm} \times 1\text{cm} \times 2\text{cm}$, you can build towers as shown in the picture. How high is a tower that is built in the same way with 28 blocks?

如圖所示，可以使用尺寸為 $1\text{cm} \times 1\text{cm} \times 2\text{cm}$ 的磚來建造塔樓。按同樣的方式使用28塊磚建造的塔樓有多高？

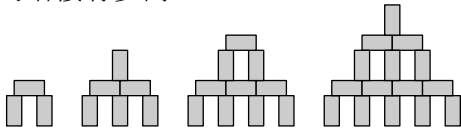

- (A) 9cm (B) 11cm (C) 12cm (D) 14cm (E) 17cm

18. Bridget folded a square sheet of paper twice, and then cut it twice as shown in the figure. How many pieces of paper will she get?

如圖所示，Bridget將一張正方紙片折疊兩次，然後剪了兩刀。問她會得到多少片紙？

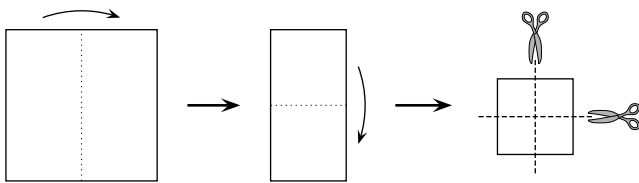

- (A) 6 (B) 8 (C) 9 (D) 12 (E) 16

19. Alex, Bob and Carl go for a walk every day. If Alex doesn't wear a hat, then Bob wears a hat. If Bob doesn't wear a hat, then Carl wears a hat. Today Bob is not wearing a hat. Who is wearing a hat?

Alex, Bob和Carl每天都去散步。如果Alex不戴帽子，那麼Bob會戴帽子。如果Bob不戴帽子，那麼Carl會戴帽子。今天Bob沒有戴帽子。問誰會戴著帽子？

- (A) Both Alex and Carl Alex和Carl (B) Only Alex 只有Alex
(C) Only Carl 只有Carl (D) Neither Alex, nor Carl Alex和Carl都沒有
(E) It is not possible to determine. 無法確定。

20. Each of the following pictures shows the net of a cube. Only one of the resulting cubes has a closed line on it. Which one?

以下每張圖片都是一個立方體的平面展開圖。折成的立方體中只有一個包含有一條閉合的線條。問是哪一個？

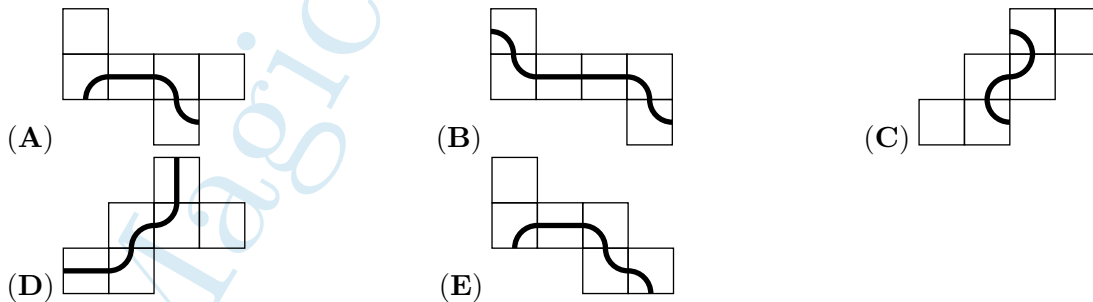

Part 3: 10 problems, 5 points each 第三部分：10道題目，每題5分
--

21. The cube shown in the figure below has a positive integer written on each face. The products of the two numbers on opposite faces are the same. What is the smallest possible sum of the six numbers on the cube?

如下圖所示的立方體的每個面上都寫有一個正整數。在相對面上的兩個數的乘積是相同的。問立方體上六個數的總和最小可能是多少？

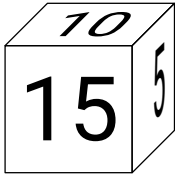

- (A) 36 (B) 37 (C) 41 (D) 44 (E) 60

22.

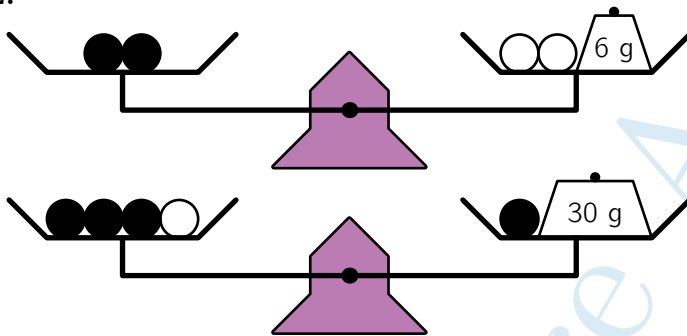

Six identical black beads and three identical white beads are arranged on weighing scales as shown in the picture. What is the total weight of these nine beads?

如圖所示，在天平上放置有六顆相同的黑色珠子和三顆相同的白色珠子。問這九顆珠子的總重量是多少？

- (A) 100 g (B) 99 g (C) 96 g (D) 94 g (E) 90 g

23. Robert made 5 statements (A) - (E), exactly one of which is false. Which one?

Robert做出了(A) - (E)的5個陳述，其中一個是假的。問是哪一個？

- (A) My son Basil has 3 sisters. 我的兒子Basil有三個姐妹。
 (B) My daughter Ann has 2 brothers. 我的女兒Ann有兩個兄弟。
 (C) My daughter Ann has 2 sisters. 我的女兒Ann有兩個姐妹。
 (D) My son Basil has 2 brothers. 我的兒子Basil有兩個兄弟。
 (E) I have 5 children. 我有5個孩子。

24. Benjamin writes an integer in the first circle and then fills the other five circles by following the instructions. How many of the six numbers in the circles are divisible by 3?

Benjamin在第一個圓圈中寫入一個整數，然後按照指示在其他五個圓圈中填數。問圓圈中的六個數有多少個能被3整除？

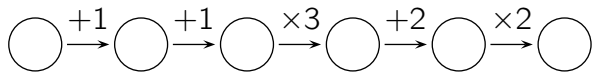

- (A) 1 1個
 (B) both 1 and 2 are possible 可能是1個或2個
 (C) 2 2個
 (D) both 2 and 3 are possible 可能是2個或者3個
 (E) both 3 and 4 are possible 可能是3個或者4個

25.

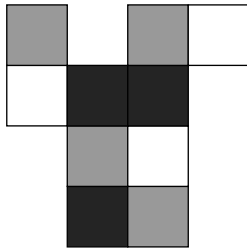

The cardboard is folded into a $2 \times 1 \times 1$ box. Which picture does NOT show this box?
 紙板折疊成一個 $2 \times 1 \times 1$ 的盒子。下面哪張圖片顯示的不是這個盒子？

- (A) (B)
 (C) (D)
 (E)

26. Emily took selfies with her 8 cousins. Each of the 8 cousins is in two or three pictures. In each picture there are exactly 5 cousins. How many selfies did Emily take?

Emily和她的八個表兄弟一起拍了自拍照。8個表兄弟中的每一個都在兩張或三張照片中。而每張照片中都恰好有5個表兄弟。問Emily拍了多少張自拍照？

- (A) 3 (B) 4 (C) 5 (D) 6 (E) 7

27. Jette and Willi are throwing balls at two identical pyramids of 15 cans. Jette knocks down 6 cans with a total of 25 points. Willi knocks down 4 cans. How many points does Willi score?

Jette和Willi向兩個完全一樣的由15個罐頭組成的金字塔擲球。Jette擊倒了6個罐頭並得到25分。Willi擊倒了4個罐頭。問Willi會得多少分？



- (A) 22 (B) 23 (C) 25 (D) 26 (E) 28

28. Every digit on my digital clock is composed of at most 7 segments, as follows:

我的數字時鐘上的每個數字最多由7段組合而成，如下所示：



But, unfortunately, in every set of 7 segments the same 2 segments don't work. 然而，在每個顯示數字的7段組中，都有相同的2段不起作用。

At this moment my clock shows

此刻我的時鐘顯示為



What will it show after 3 hours and 45 minutes?

問3小時45分鐘後會怎樣顯示？

- (A) (B) (C)
- (D) (E)

29. Linas builds a $4 \times 4 \times 4$ cube using 32 white and 32 black $1 \times 1 \times 1$ cubes. He arranges the cubes so that as much of the surface of his large cube is white. What fraction of the surface of his cube is white?

Linas使用32個白色和32個黑色 $1 \times 1 \times 1$ 立方體構建一個 $4 \times 4 \times 4$ 立方體。他排列這些立方體使得大立方體的表面上有盡可能多的是白色。問大立方體的表面中白色佔幾分之幾？

- (A) $\frac{1}{4}$ (B) $\frac{1}{2}$ (C) $\frac{2}{3}$ (D) $\frac{3}{4}$ (E) $\frac{3}{8}$

30. Zev has two machines: one exchanges 1 white token into 4 red tokens, while the other exchanges 1 red token into 3 white ones. Zev has 4 white tokens. After exactly 11 exchanges, he has 31 tokens. How many of those are red?

Zev有兩台機器：一台將1個白色代幣換成4個紅色代幣，而另一台則將1個紅色代幣換成3個白色代幣。Zev有4個白色代幣。經過恰好11次交換，他有31個代幣。問其中有多少個是紅色的？

- (A) 21 (B) 17 (C) 14 (D) 27 (E) 11